



TSR immersion probes

**Controlling devices with
magnetically operated reed contacts,
for automatic control,
regulation and signalling of liquid levels**



Jola Spezi schalter GmbH & Co. KG
Klostergartenstr. 11 • 67466 Lambrecht (Germany)
Tel. +49 6325 188-01 • Fax +49 6325 6396
contact@jola-info.de • www.jola-info.de



TSR immersion probes

Contents					Page		
General information					3-1-2		
Switching examples and circuit diagrams					3-1-3		
Type	Probe tube		Float				
	Material	Ø	Material	Dimensions			
TSR./ED/P	stainless steel 316 Ti	12 mm	PP	53 mm Ø x 50 mm	3-1-5		
TSR./ED/PK				29 mm Ø x 50 mm	3-1-5		
TSR./ED/E8			stainless steel 316 Ti	12 mm	stainless steel 316 Ti	72 mm Ø	3-1-7
TSR./ED/E2						44.5 mm Ø x 52 mm	3-1-7
TSR./ED/E7						52 mm Ø x 88 mm	3-1-7
TSR./ED/E5						98 mm Ø	3-1-9
TSR./EW/E5	20 mm	98 mm Ø	3-1-9				
TSR./P/P	PP	14 mm	PP	53 mm Ø x 50 mm	3-1-11		
TSR./P/PG		16 mm		89 mm Ø x 60 mm	3-1-11		
TSR./PVDF/D	PVDF	14 mm	PVDF	53 mm Ø x 50 mm	3-1-13		
TSR./PVDF/W		16 mm		89 mm Ø x 60 mm	3-1-13		
TSR./TiD/Ti7	titanium	12 mm	titanium	44.5 mm Ø x 52 mm	3-1-15		
TSR./TiW/Ti4		19 or 20 mm		79 mm Ø x 95 mm	3-1-15		
TSR/0/ED/E6	stainless steel 316 Ti	12 mm	stainless steel 316 Ti	44.5 mm Ø x 47.5 mm	3-1-17		
DK3 switching bowls					3-1-18		
Questionnaire for inquiries and orders					3-1-19		

The units described in this documentation may only be installed, connected and started up by suitably qualified personnel!

Subject to deviations from the diagrams and technical data.

The details in this brochure are product specification descriptions and do not constitute assured properties in the legal sense.

TSR immersion probes



Magnetically operated automatic liquid level controls

Construction and operating principle of TSR immersion probes

The TSR immersion probes have a probe tube with built-in reed contacts. The float is fitted with a permanent magnet and moves freely up and down the probe tube, activating the reed contacts as it rises and falls.

It should be noted that reed contacts do **not** lock but that they switch only for as long as they are influenced by the magnetic field. Once the float passes beyond a contact upwards or downwards, the latter returns to its original position. However, the contacts can be made to hold by using collars to limit the motion of the float.

For use outside potentially explosive atmospheres, the customer can choose the model TSR/3/... or TSR/1/... (not suitable for the type TSR/0/ED/E6, see page 3-1-17):

Type	TSR/3/...	TSR/1/...
Application Switching voltage Switching current Switching capacity	for applications up to max. 250 V AC/DC 24 V – 250 V AC 100 mA – 2 A (0.4 A) max. 100 VA	for light current applications AC/DC 1 V – 42 V AC 1 mA – 500 mA max. 20 VA
VDE marks licences	 + 	
Instruction for working with inductive loads: When using the TSR types with inductive loads, a RC combination of 0.22 μ F + 220 Ω must be connected in parallel to the magnetic coil of the contactor.		

Caution!

If a TSR immersion probe is to be used with a KR protection relay, you must choose the model TSR/1/... .

We recommend this apparatus combination.

Specimen application 1: Automatic emptying of a tank

The float rises with the liquid to the maximum level and trips the “make” (= normally open) contact which in turn activates the contactor solenoid, serving, for example, to set a pump in operation. Liquid is pumped out. When the minimum level is reached, the “break” (= normally closed) contact at the bottom is activated, thus interrupting the contactor holding circuit. The arrangement is therefore exactly the same as with ON-OFF pushbuttons.

Specimen application 2: Automatic filling of a tank

The float falls with the liquid to the minimum level and trips the “make” (= normally open) contact which in turn activates the contactor solenoid, serving, for example, to set a pump in operation. Liquid is then pumped in. When the maximum level is reached, the upper “break” (= normally closed) contact is activated, thus interrupting the contactor holding circuit. The arrangement is therefore exactly the same as with ON-OFF pushbuttons.

Examples of standard operation

Standard operations with 1 float and a collar fitted above the upper contact.

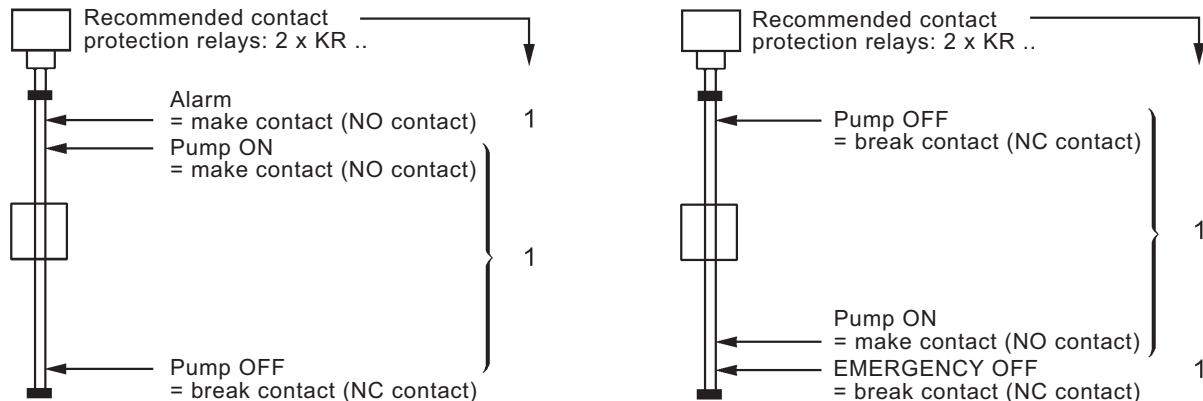

The collar fitted at the top stops the float at the upper contact, so that the latter cannot be overrun. If this collar was not fitted, it is conceivable that, in the case of a short power failure and freely entering liquid, for example, the contact for “Pump ON” or the alarm contact would be overrun during the short power failure without the pump being switched on or an alarm signal being given. This could then lead to an overflow.

For the same reasons, the probe tube should be of such a length that when the float reaches the lower contact, it rests on the lower holding washer or collar (For information on the recommended distances between contact and end of probe tube, see the technical data of the individual TSR models under “Minimum distances”).

Standard operations with 2 or more floats

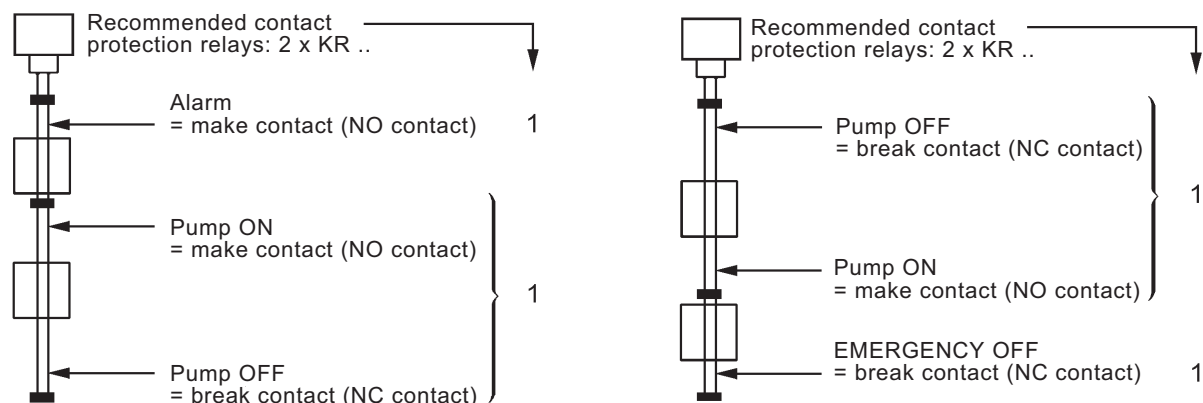

The use of an additional float together with the corresponding collar ensures that not only the uppermost and lowest but also another important contact is held when the liquid level rises above or falls below the level at which the contact is set. Depending on the desired switching function, it is possible to use several floats together with the corresponding collars.

When fixing the levels at which the contacts are to be set, care should be taken to ensure that wherever a float is stopped at a contact by a collar, the minimum distance to an adjacent contact activated by another, separate float should be increased in varying degrees, depending on the model of floats planned. Please consult us regarding exact spacing!

Basic circuit diagram for emptying

Basic circuit diagram for filling

using a TSR

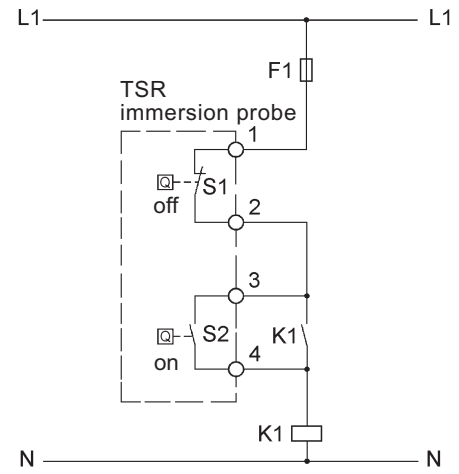
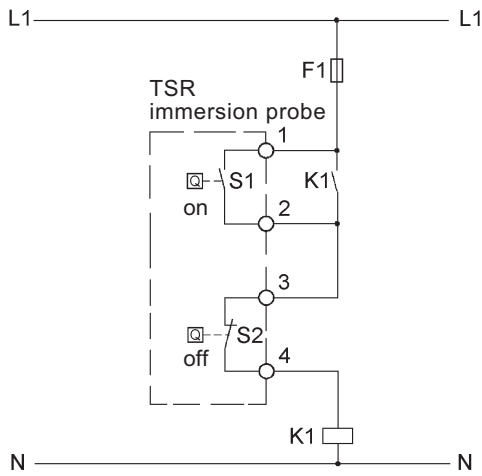

using a TSR for 2 pumps

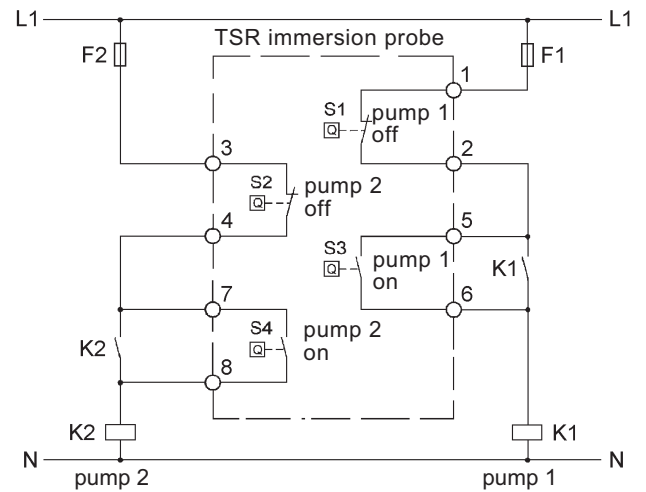
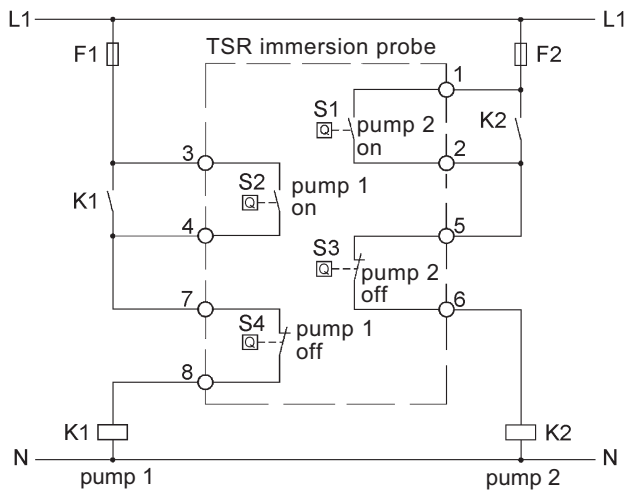

using a TSR for 2 pumps with a common switch-off contact

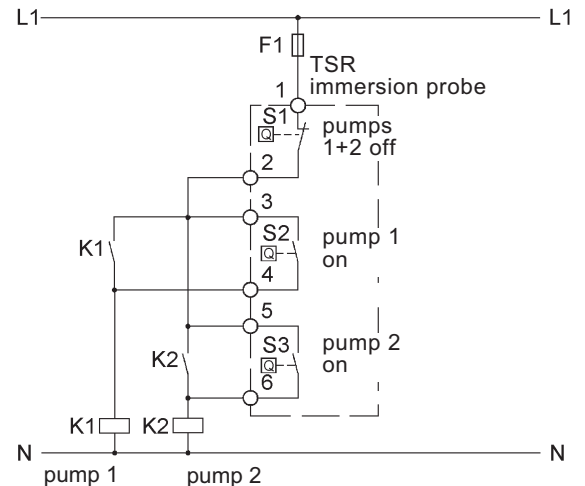
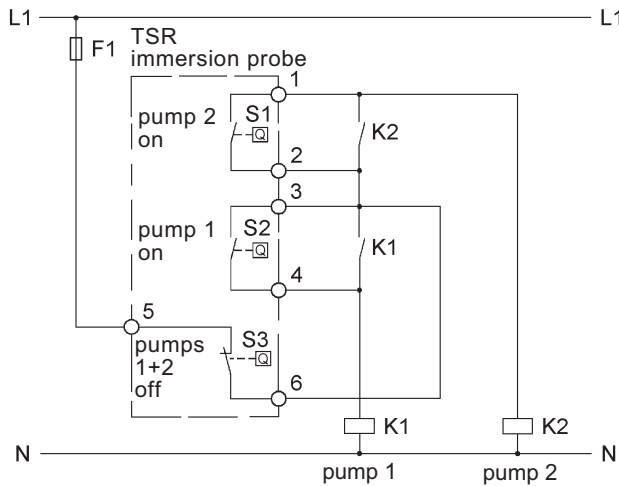

The above contact positions correspond to a liquid level situated between the respective switch-on and switch-off points.



TSR/... immersion probes with

- probe tube made of stainless steel
- float made of PP

Type	TSR/3/ED/..	TSR/1/ED/..
Application	for applications up to max. 250 V	for light current applications
Switching voltage	AC/DC 24 V – 250 V	AC/DC 1 V – 42 V
Switching current	AC 100 mA – 2 A (0.4 A)	AC 1 mA – 500 mA
Switching capacity	max. 100 VA	max. 20 VA
Technical data	TSR/3/ED/P TSR/1/ED/P	TSR/3/ED/PK TSR/1/ED/PK
Probe tube: material	stainless steel 316 Ti	
diameter	12 mm	
length	acc. to customer's specification, however max. 3,000 mm	
Screw-in nipple	G ^{1/2} , on request G1, G1, on request G ^{1/2} , on request G1 ^{1/2} or G2; on request with reducing nipple made of malleable cast iron R1 ^{1/2} or R2 conical	
Float	PP, 53 mm Ø x 50 mm (mounting possible through a G/R2 socket)	29 mm Ø x 50 mm (mounting possible through a G1 socket)
Float suitable for use in media with a specific gravity	≥ 0.8 g/cm ³	≥ 0.85 g/cm ³
Terminal box	PP, A 307, 120 x 80 x 55 mm, protection class IP65, with max. 12 terminals; other terminal boxes on request; with free connecting cable on request	
Mounting orientation	vertical	
Temperature range	– 20°C to + 80°C	
Pressure resistance at + 20°C	max. 2 bar	
Contacts	reed contacts: make (NO), break (NC) or changeover (OC)	
Max. number of contacts	3	
Min. distances to be observed (based on liquids with a specific gravity of 1 g/cm ³):		
• from the nipple sealing surface to the upper contact	approx. 70 mm	approx. 70 mm
• between contacts	approx. 80 mm	approx. 80 mm
• from the lower contact to the end of the probe tube (when float is falling)	approx. 40 mm	approx. 50 mm

Also available with angled probe tube for mounting from the side

The above equipment will be manufactured in accordance with your specifications

For inquiries or orders, please complete the questionnaire on page 3-1-19

Option for TSR/1/... immersion probes: diodes or resistors

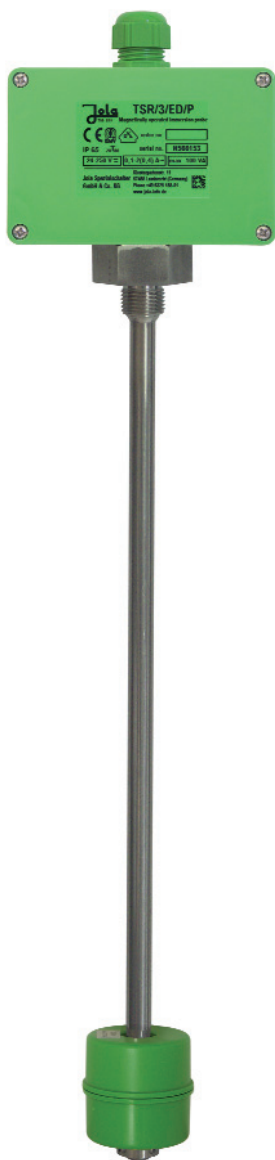
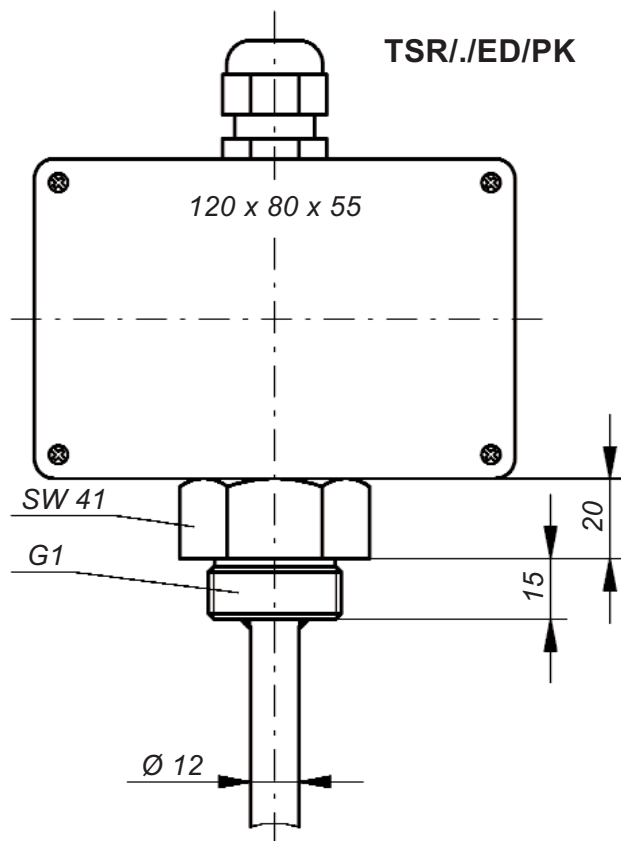
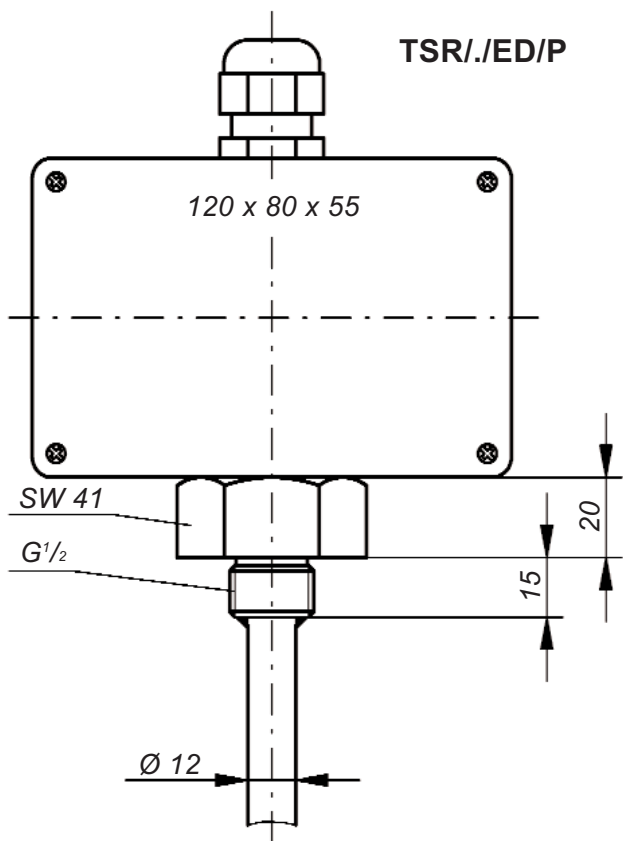

TSR/3/ED/P



TSR/3/ED/PK

**Float for
TSR./ED/P**

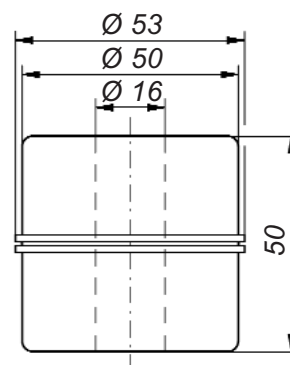

**Float for
TSR./ED/PK**

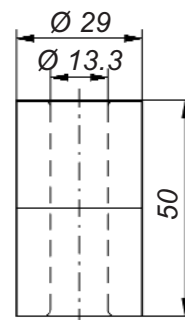

Mounting accessories:

Square flange made of stainless steel 316 Ti, PP or PVDF for immersion probes with G1 screw-in nipple, counterflange on request



TSR/... immersion probes with

- probe tube made of stainless steel
- float made of stainless steel

Type	TSR/3/ED/E.	TSR/1/ED/E.
Application	for applications up to max. 250 V	for light current applications
Switching voltage	AC/DC 24 V – 250 V	AC/DC 1 V – 42 V
Switching current	AC 100 mA – 2 A (0.4 A)	AC 1 mA – 500 mA
Switching capacity	max. 100 VA	max. 20 VA

Technical data	TSR/3/ED/E8 TSR/1/ED/E8	TSR/3/ED/E2 TSR/1/ED/E2	TSR/3/ED/E7 TSR/1/ED/E7
Probe tube: material	stainless steel 316 Ti		
diameter	12 mm		
length	acc. to customer's specification, however max. 3,000 mm		
Screw-in nipple	G ^{1/2} , on request G1, G1 ^{1/2} or G2; — on request with reducing nipple made of malleable cast iron		
		R1 ^{1/2} conical	R2 conical
Float	72 mm Ø	stainless steel 316 Ti, 44.5 mm Ø x 52 mm	52 mm Ø x 88 mm
		mounting possible through a G/R1 ^{1/2} socket G/R2 socket	
Float suitable for use in media with a specific gravity	≥ 0.7 g/cm ³	≥ 0.95 g/cm ³	≥ 0.7 g/cm ³
Terminal box	PP, A 307, 120 x 80 x 55 mm, protection class IP65, for max. 12 terminals; other terminal boxes on request; with free connecting cable on request		
Mounting orientation	vertical		
Temperature range	– 20°C to + 100°C; on request: – 20°C to + 130°C		
Pressure resistance at + 20°C	max. 12 bar, higher pressure resistance on request		
Contacts	reed contacts: make (NO), break (NC) or changeover (OC)		
Max. number of contacts	3		
Min. distances to be observed (based on liquids with a specific gravity of 1 g/cm ³):			
• from the nipple sealing surface to the upper contact	approx. 80 mm	approx. 70 mm	approx. 80 mm
• between contacts	approx. 80 mm	approx. 80 mm	approx. 80 mm
• from the lower contact to the end of the probe tube (when float is falling)	approx. 60 mm	approx. 60 mm	approx. 70 mm

Also available with angled probe tube for mounting from the side

The above equipment will be manufactured in accordance with your specifications

For inquiries or orders, please complete the questionnaire on page 3-1-19

Option for TSR/1/... immersion probes: diodes or resistors

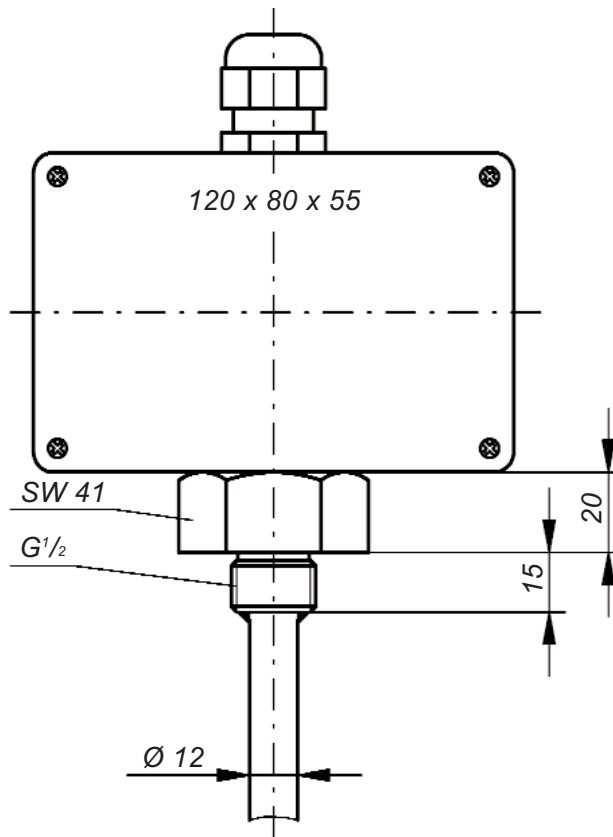

**Float for
TSR/.ED/E8**

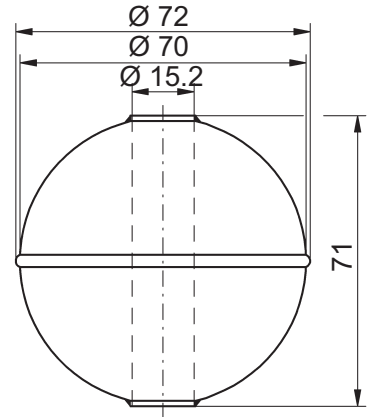

**Float for
TSR/.ED/E2**

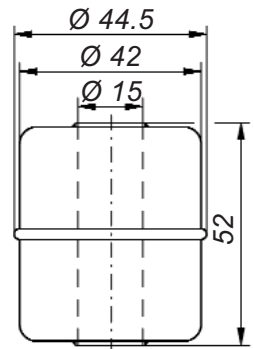

**Float for
TSR/.ED/E7**

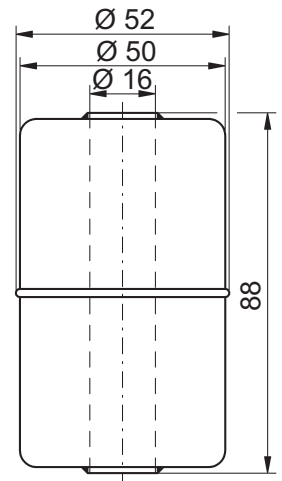

TSR/3/ED/E8

TSR/3/ED/E2

TSR/3/ED/E7

Mounting accessories:

Square flange made of stainless steel 316 Ti, PP or PVDF for immersion probes with G1 screw-in nipple, counterflange on request



TSR/... immersion probes with

- probe tube made of stainless steel
- float made of stainless steel

Type	TSR/3/E./E5	TSR/1/E./E5
Application	for applications up to max. 250 V	for light current applications
Switching voltage	AC/DC 24 V – 250 V	AC/DC 1 V – 42 V
Switching current	AC 100 mA – 2 A (0.4 A)	AC 1 mA – 500 mA
Switching capacity	max. 100 VA	max. 20 VA
Technical data	TSR/3/ED/E5 TSR/1/ED/E5	TSR/3/EW/E5 TSR/1/EW/E5
Probe tube: material	stainless steel 316 Ti	
diameter	12 mm	20 mm
length	acc. to customer's specification, however	
	max. 3,000 mm	max. 6,000 mm
Screw-in nipple	G ¹ / ₂ , on request G1,	G1,
	on request G ¹ / ₂ or G2;	
	on request with reducing nipple made of malleable cast iron R ¹ / ₂ or R2 conical	
Float	stainless steel 316 Ti,	
	98 Ø mm	98 Ø mm or
		97 mm Ø x 80 mm
		(heat-resistant version with float E4)
Float suitable for use in media with a specific gravity	≥ 0.7 g/cm ³	
Terminal box	PP, A 307, 120 x 80 x 55 mm, protection class IP65, with max. 12 terminals; other terminal boxes on request; with free connection cable on request	
Mounting orientation	vertical	
Temperature range	– 20°C to + 100°C	– 20°C to + 100°C ; on request: – 20°C to + 130°C
Pressure resistance at + 20°C	max. 12 bar,	max. 12 bar (heat-resistant version: max. 3 bar),
	higher pressure resistance on request	
Contacts	reed contacts: make (NO), break (NC) or changeover (OC)	
Max. number of contacts	3	6, more on request
Min. distances to be observed (based on liquids with a specific gravity of 1 g/cm³):		
• from the nipple sealing surface to the upper contact	approx. 90 mm	approx. 90 mm
• between contacts	approx. 80 mm	approx. 80 mm
• from the lower contact to the end of the probe tube (when float is falling)	approx. 60 mm	approx. 70 mm

Also available with angled probe tube for mounting from the side

The above equipment will be manufactured in accordance with your specifications

For inquiries or orders, please complete the questionnaire on page 3-1-19

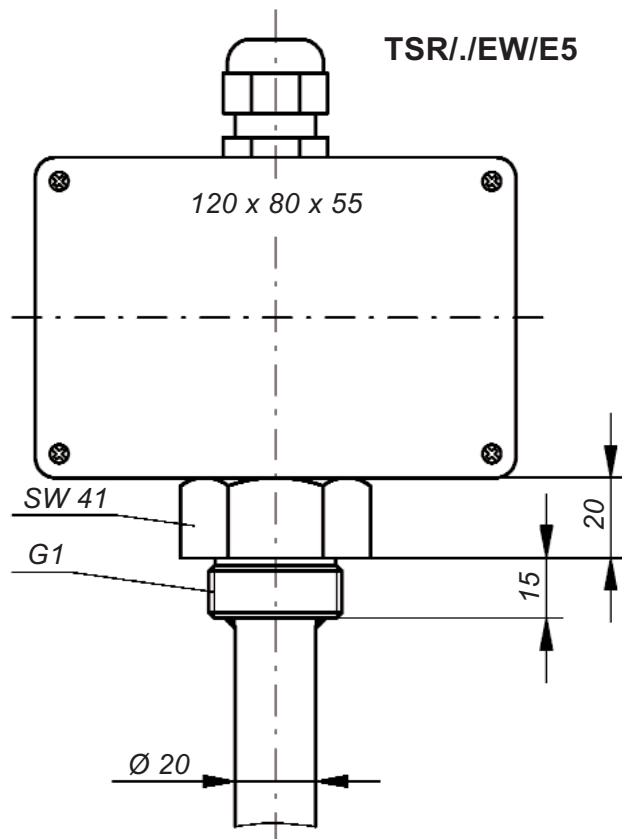
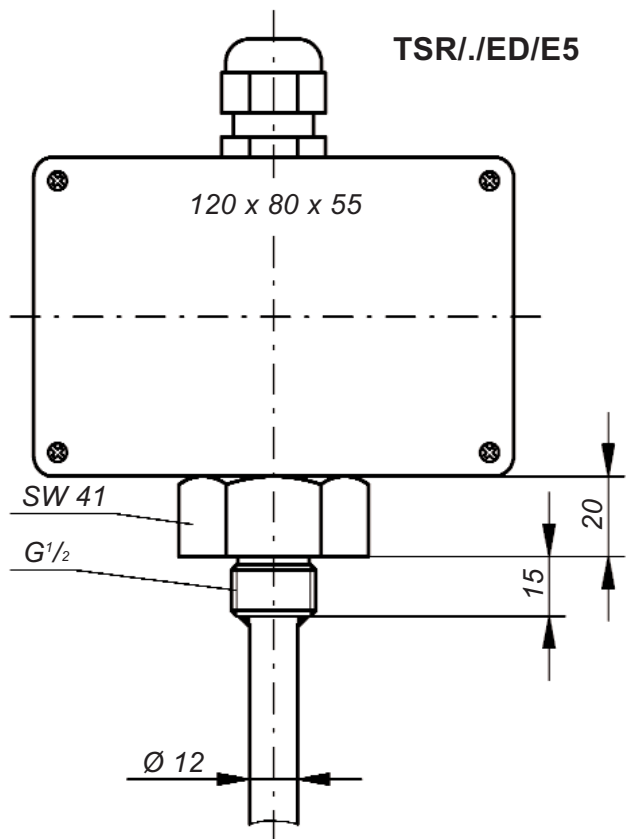

TSR/3/ED/E5



TSR/3/EW/E5

**Float for
TSR./ED/E5
and
TSR./EW/E5**

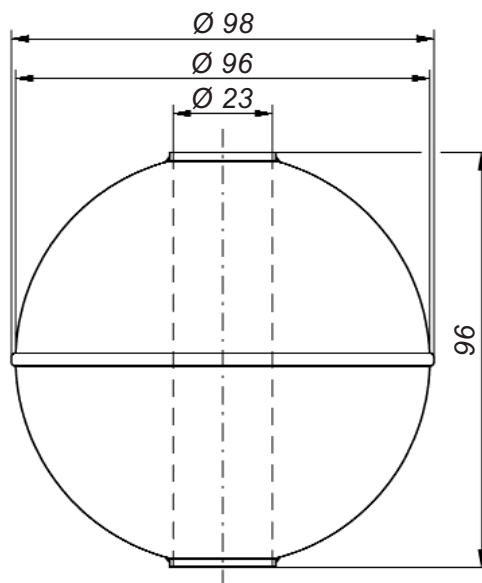



TSR/... immersion probes with

- probe tube made of PP
- float made of PP

Type	TSR/3/P/P	TSR/1/P/PG
Application	for applications up to max. 250 V AC/DC 24 V – 250 V	for light current applications AC/DC 1 V – 42 V
Switching voltage	AC/DC 24 V – 250 V	AC/DC 1 V – 42 V
Switching current	AC 100 mA – 2 A (0.4 A)	AC 1 mA – 500 mA
Switching capacity	max. 100 VA	max. 20 VA
Technical data	TSR/3/P/P TSR/1/P/P	TSR/3/P/PG TSR/1/P/PG
Probe tube: material	—	PP, on request, with metal inner tube to strengthen the plastic probe tube
diameter	14 mm	16 mm
length	according to customer's specifications, however max. 1,000 mm, taking into account the max. temperature in the tank and possible liquid turbulences	max. 2,000 mm,
Screw-in nipple	G1,	G1, on request: G2
Float	53 mm Ø x 50 mm (mounting possible through a G2 socket)	89 mm Ø x 60 mm
Float suitable for use in media with a specific gravity	≥ 0.8 g/cm ³	
Terminal box	PP, A 307, 120 x 80 x 55 mm, protection class IP65, with max. 12 terminals; other terminal boxes on request; with free connecting cable on request	
Mounting orientation	vertical	
Temperature range taking into account the probe tube length:		
– max. 2,000 mm	—	0°C to + 35°C
– max. 1,500 mm	—	0°C to + 40°C
– max. 1,000 mm		0°C to + 50°C
– max. 750 mm		0°C to + 60°C
– max. 500 mm		0°C to + 75°C
– max. 400 mm		0°C to + 80°C
Pressure resistance at + 20°C	max. 2 bar	
Contacts	reed contacts: make (NO), break (NC) or changeover (OC)	
Max. number of contacts:		
• without inner tube	3	6
• with inner tube	—	3
Min. distances to be observed (based on liquids with a specific gravity of 1 g/cm ³):		
• from the nipple sealing surface to the upper contact	approx. 70 mm	approx. 80 mm
• between contacts	approx. 80 mm	approx. 80 mm
• from the lower contact to the end of the probe tube (when float is falling)	approx. 60 mm	approx. 50 mm

The above equipment will be manufactured in accordance with your specifications

For inquiries or orders, please complete the questionnaire on page 3-1-19

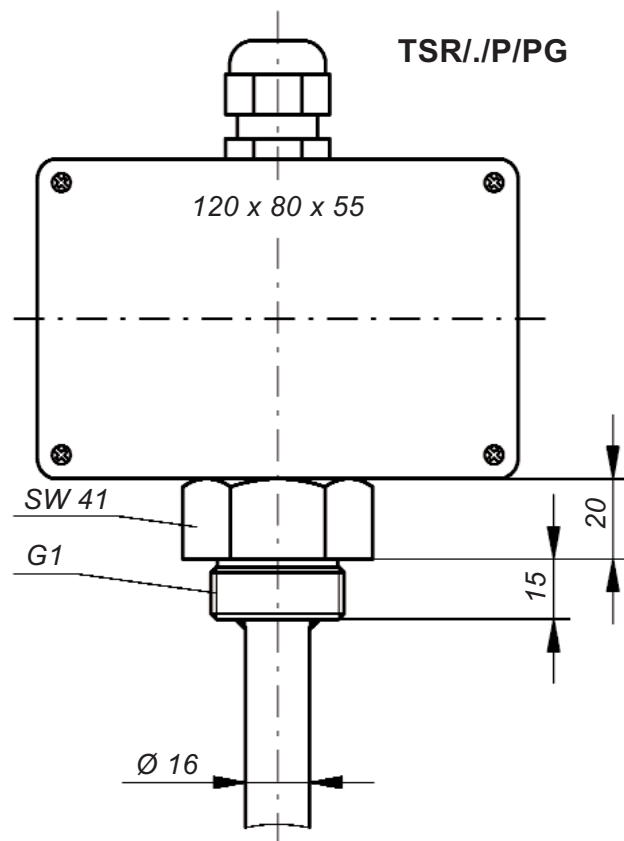
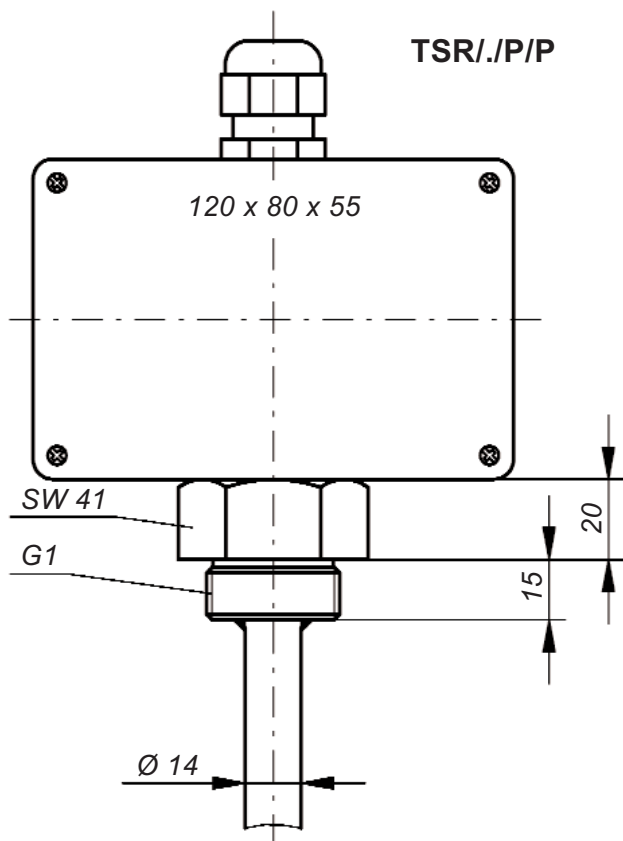

TSR/3/P/P



TSR/3/P/PG

Float for
TSR./P/P

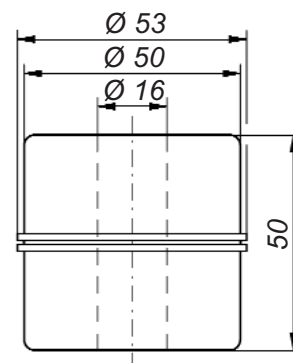

Float for
TSR./P/PG

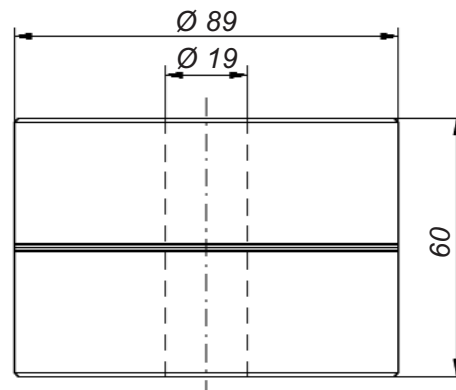

Mounting accessories:
Square flange made of PP
for immersion probes with
G1 screw-in nipple,
counterflange on request



TSR/... immersion probes with

- probe tube made of PVDF
- float made of PVDF

Type	TSR/3/PVDF/.	TSR/1/PVDF/.
Application	for applications up to max. 250 V	for light current applications
Switching voltage	AC/DC 24 V – 250 V	AC/DC 1 V – 42 V
Switching current	AC 100 mA – 2 A (0.4 A)	AC 1 mA – 500 mA
Switching capacity	max. 100 VA	max. 20 VA
Technical data	TSR/3/PVDF/D TSR/1/PVDF/D	TSR/3/PVDF/W TSR/1/PVDF/W
Probe tube: material	—	PVDF, on request, with metal inner tube to strengthen the plastic probe tube
diameter	14 mm	16 mm
length	according to customer's specifications, however max. 1,000 mm, taking into account the max. temperature in the tank and possible liquid turbulences	according to customer's specifications, however max. 2,000 mm, taking into account the max. temperature in the tank and possible liquid turbulences
Screw-in nipple	G1,	G1, on request: G2
Float	53 mm Ø x 50 mm (mounting possible through a G2 socket)	89 mm Ø x 60 mm
Float suitable for use in media with a specific gravity	≥ 1 g/cm ³	≥ 1 g/cm ³
Terminal box	PP, A 307, 120 x 80 x 55 mm, protection class IP65, with max. 12 terminals; other terminal boxes on request; with free connecting cable on request	
Mounting orientation	vertical	
Temperature range taking into account the probe tube length:		0°C to + 40°C
– max. 2,000 mm	—	0°C to + 45°C
– max. 1,500 mm	—	0°C to + 55°C
– max. 1,000 mm		0°C to + 70°C
– max. 750 mm		0°C to + 80°C
– max. 500 mm		max. 2 bar
Pressure resistance at + 20°C	reed contacts: make (NO), break (NC) or changeover (OC)	
Contacts		
Max. number of contacts:		
• without inner tube	3	6
• with inner tube	—	3
Min. distances to be observed (based on liquids with a specific gravity of 1 g/cm ³):		
• from the nipple sealing surface to the upper contact	approx. 80 mm	approx. 80 mm
• between contacts	approx. 80 mm	approx. 80 mm
• from the lower contact to the end of the probe tube (when float is falling)	approx. 70 mm	approx. 65 mm

The above equipment will be manufactured in accordance with your specifications

For inquiries or orders, please complete the questionnaire on page 3-1-19

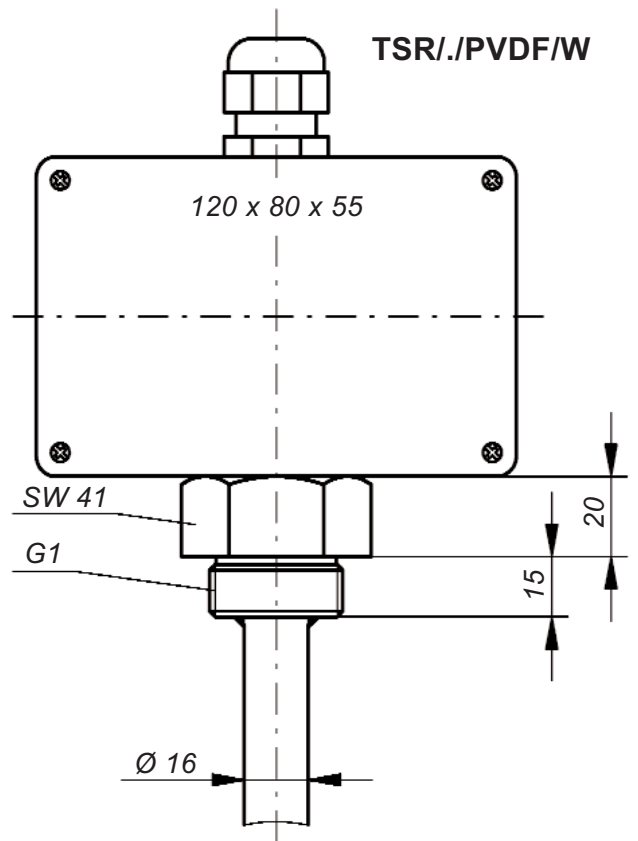
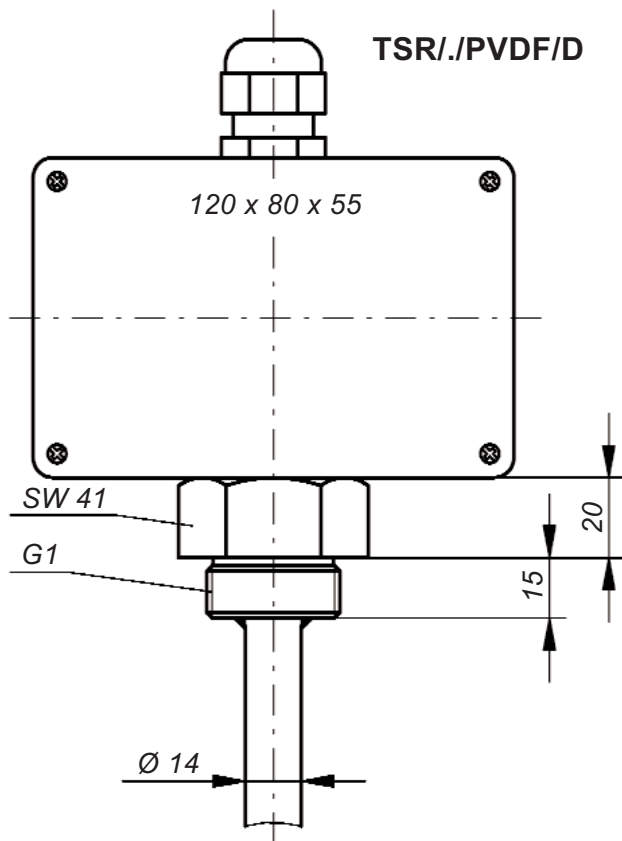

TSR/3/PVDF/D

TSR/3/PVDF/W

Float for
TSR./PVDF/D

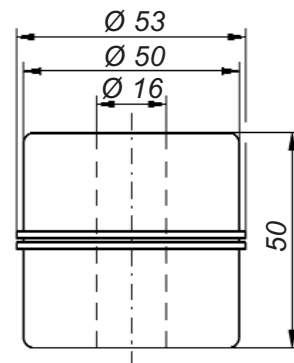

Float for
TSR./PVDF/W

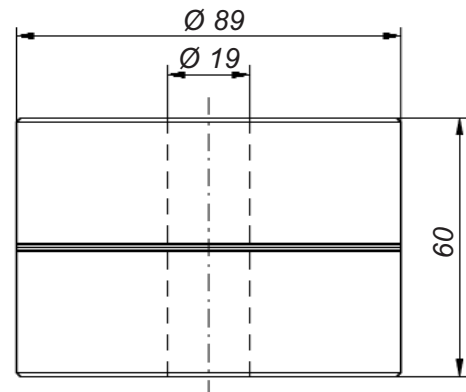

Mounting accessories:

Square flange made of PVDF for immersion probes with G1 screw-in nipple, counterflange on request



TSR/... immersion probes with

- probe tube made of titanium
- float made of titanium

Type	TSR/3/Ti./Ti.	TSR/1/Ti./Ti.
Application	for applications up to max. 250 V	for light current applications
Switching voltage	AC/DC 24 V – 250 V	AC/DC 1 V – 42 V
Switching current	AC 100 mA – 2 A (0.4 A)	AC 1 mA – 500 mA
Switching capacity	max. 100 VA	max. 20 VA

Technical data	TSR/3/TiD/Ti7 TSR/1/TiD/Ti7	TSR/3/TiW/Ti4 TSR/1/TiW/Ti4
Probe tube: material diameter length	titanium 12 mm according to customer's specifications, however max. 3,000 mm	titanium 19 or 20 mm max. 6,000 mm
Screw-in nipple	G ^{1/2}	G1
Float	titanium, 44.5 mm Ø x 52 mm	79 mm Ø x 95 mm
Float suitable for use in media with a specific gravity	≥ 0.95 g/cm ³	≥ 0.7 g/cm ³
Terminal box	PP, A 307, 120 x 80 x 55 mm, protection class IP65, with max. 12 terminals; other terminal boxes on request; with free connecting cable on request	
Mounting orientation	vertical	
Temperature range	– 20°C to + 100°C	
Pressure resistance at + 20°C	max. 10 bar, higher pressure resistance on request	max. 7 bar, higher pressure resistance on request
Contacts	reed contacts: make (NO), break (NC) or changeover (OC)	
Max. number of contacts	3	6, more on request
Min. distances to be observed (based on liquids with a specific gravity of 1 g/cm ³):		
• from the nipple sealing surface to the upper contact	approx. 70 mm	approx. 90 mm
• between contacts	approx. 80 mm	approx. 80 mm
• from the lower contact to the end of the probe tube (when float is falling)	approx. 60 mm	approx. 75 mm

Also available with angled probe tube for mounting from the side

The above equipment will be manufactured in accordance with your specifications

For inquiries or orders, please complete the questionnaire on page 3-1-19

Option for TSR/1/... immersion probes: diodes or resistors

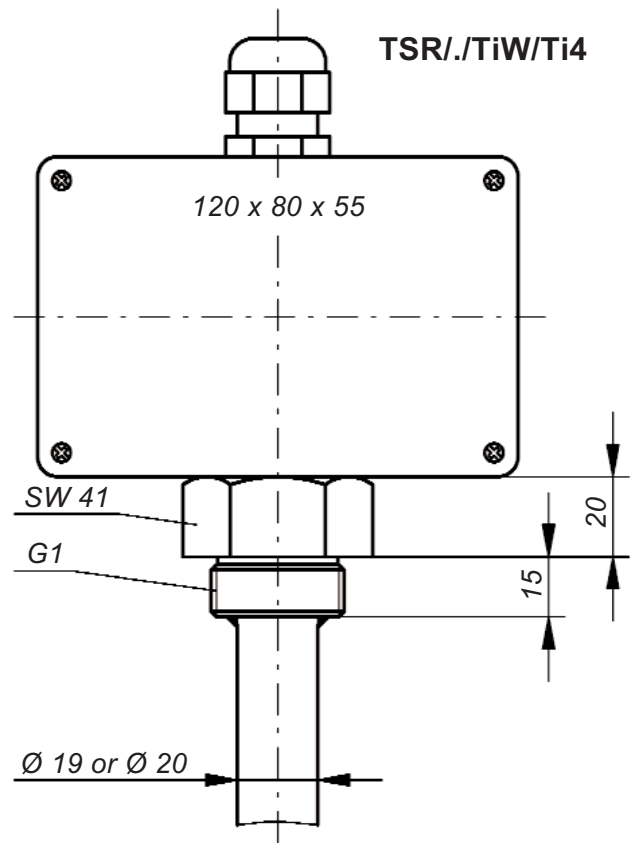
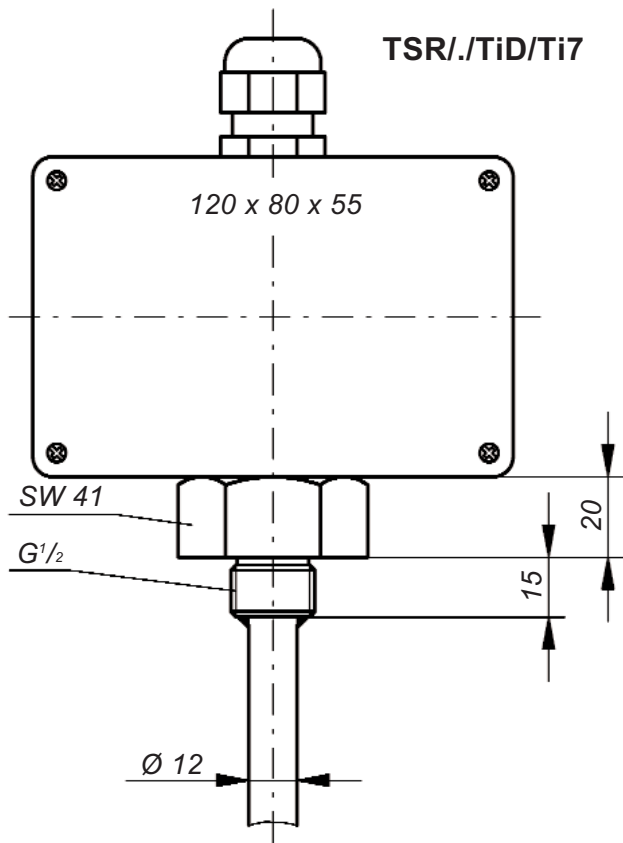

TSR./TiD/Ti7

TSR./TiW/Ti4

**Float for
TSR./TiD/Ti7**

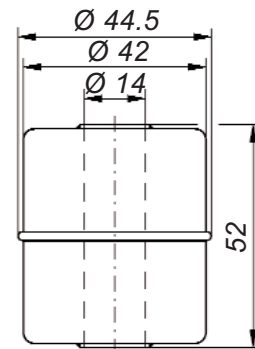

**Float for
TSR./TiW/Ti4**

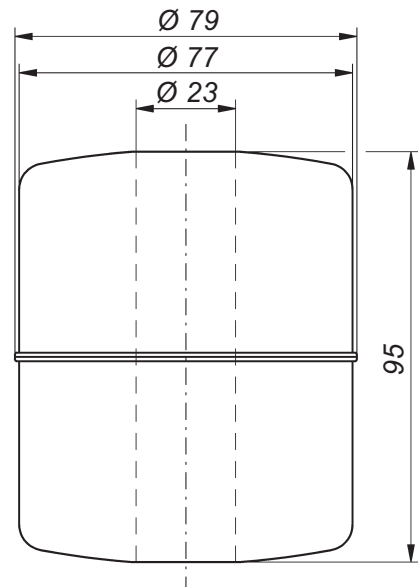



TSR/0/ED/E6 immersion probe with

- probe tube made of stainless steel
- float made of stainless steel

with mini-contacts for small contact distances and/or a higher number of contacts

Types	TSR/0/ED/E6
Application Switching voltage Switching current Switching capacity	for light current applications AC/DC 1 V - 42 V AC 1 mA - 100 mA max. 2 VA

Technical data	TSR/0/ED/E6
Probe tube: material diameter length	stainless steel Ti 12 mm acc. to customer's specifications, however max. 3,000 mm
Screw-in nipple	G $\frac{1}{2}$, on request G1, G1 $\frac{1}{2}$ or G2; on request with reducing nipple made of malleable cast iron R1 $\frac{1}{2}$ or R2 conical
Float	stainless steel 316 Ti, 44.5 mm \varnothing x 47.5 mm (mounting possible through a G/R1 $\frac{1}{2}$ socket)
Float suitable for use in media with a specific gravity	$\geq 0.95 \text{ g/cm}^3$
Terminal box	PP, A 307, 120 x 80 x 55 mm, protection class IP65, with max. 12 terminals; other boxes on request
Mounting orientation	vertical
Temperature range	- 20°C to + 100°C
Pressure resistance to + 20°C	max. 12 bar
Contacts	reed contacts: make (NO), break (NC) or changeover (OC)
Max. number of contacts	6
Min. distances to be observed (based on liquids with a specific gravity of 1 g/cm 3):	
• from the nipple sealing surface to the upper contact	approx. 50 mm
• between contacts	approx. 20 mm
• from the lower contact to the end of the probe tube (when float is falling)	approx. 50 mm
Also available with angled probe tube for mounting from the side	

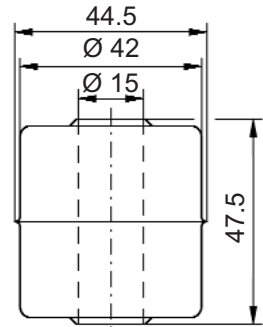

**Float for
TSR/0/ED/E6**

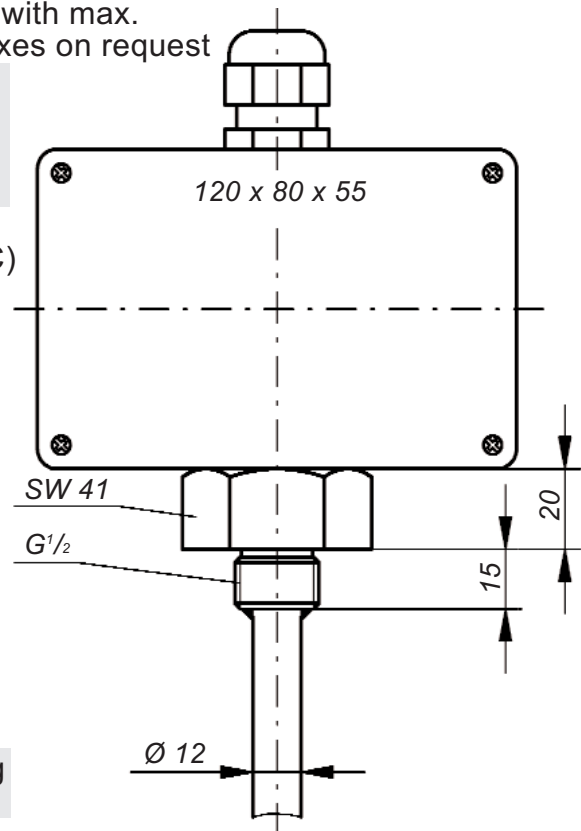

The above equipment will be manufactured in accordance with your specifications

For inquiries or orders, please complete the questionnaire on page 3-1-19



DK 3 switching bowls

For lateral mounting on tanks or pipelines, suitable for TSR immersion probes.

The use of a switching bowl is necessary wherever heavy turbulences would impede or prevent the operation of an immersion probe inside a tank or where these units cannot be installed for reasons of space.

Technical data	DK 3
Material	stainless steel 316 Ti; other materials on request
Diameter	102 mm
Height	according to customer's specifications
Socket size	according to customer's specifications; on request: flanges of any dimensions
Distance between sockets (or flanges)	according to customer's specifications

**DK 3 switching bowl:
standard model**

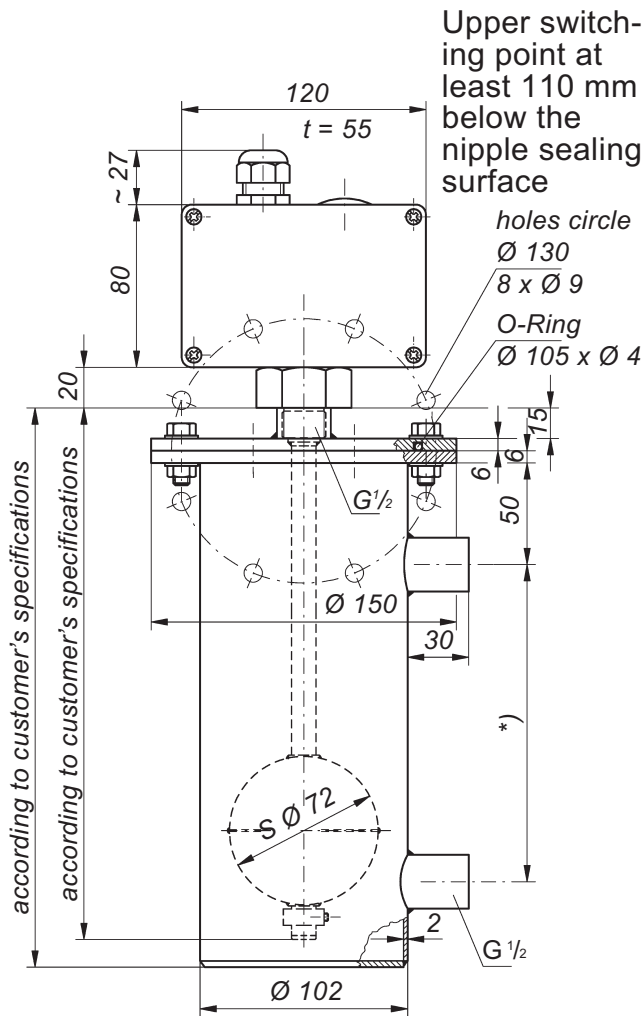

**DK 3 switching bowl:
special design with gauge glass and
4 sockets**

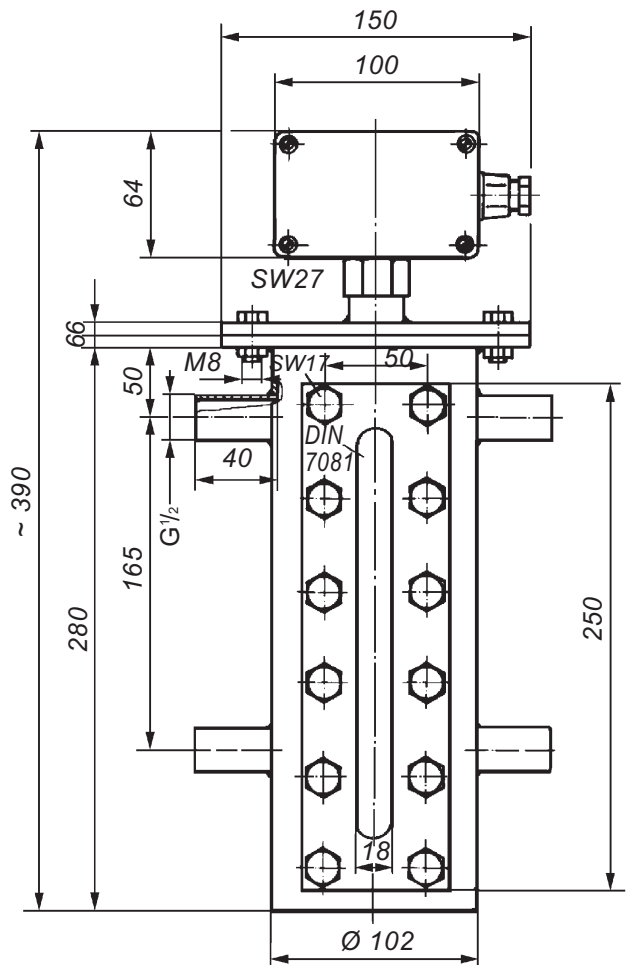

*) according to customer's specifications

Other dimensions on request.

For inquiries or orders, please complete the following questionnaire:

Desired switching functions
(max./min. indication, pump or
valve ON/OFF, filling or emptying,
run-dry or overflow protection):

Tank dimensions and installation
conditions
(attach sketch if necessary):

Type of liquid: _____ Specific gravity: _____

Viscosity: _____ Temperature: _____ Working pressure: _____

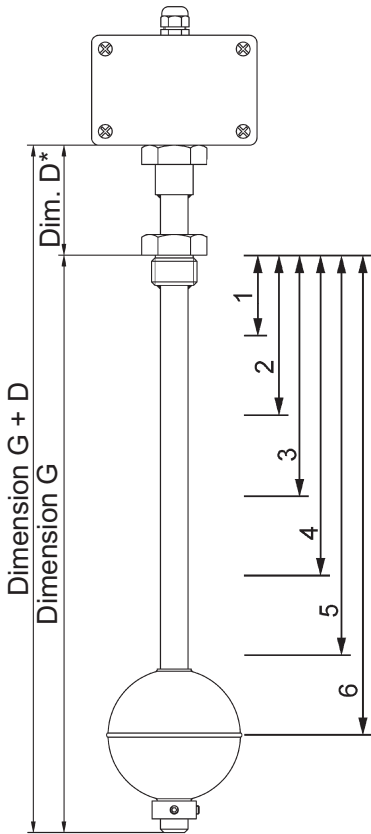

Desired type of immersion probe: TSR/.....

Desired probe tube length (dimension G):

Please mark desired floats and collars on the probe tube!
* = specify dimension D, otherwise 20 mm.

Desired version (please tick off):

	<input type="radio"/> TSR/3/...	<input type="radio"/> TSR/1/...
Switching voltage	AC/DC 24 V – 250 V	AC/DC 1 V – 42 V
Switching current	AC 100 mA – 2 A (0.4 A)	AC 1 mA – 500 mA
Switching capacity	max. 100 VA	max. 20 VA

TSR/0/ED/E 6

Desired options:

	Contact type: make = NO break = NC changeover = OC	Distance from the sealing surface of the screw-in nipple in mm	Switching function (e.g. high alarm, pump ON, pump OFF etc.)	If float has a working direction: rising = ↑ falling = ↓
1				
2				
3				
4				
5				
6				

Immersion probes will be manufactured according to customer's specifications. It is therefore not possible to return these special designs.